



T&S PARAMETERS

$F(s) = 49 \text{ Hz}$
 $Q(ms) = 8.254$
 $V(as) = 75 \text{ liters}$
 $M(ms) = 61 \text{ grams}$
 $R(ms) = 2.27 \text{ kg/s}$
 $S(d) = 551 \text{ sq.cm}$
 $V(d) = 0.441 \text{ liters}$
 $R(e) = 5.4 \text{ ohms}$
 $Q(es) = 0.453$
 $C(ms) = 0.173 \text{ mm/N}$
 $Q(ts) = 0.43$
 $L(e) \text{ 1kHz} = 1.08 \text{ mH}$
 $BL = 15$
 $n(0) = 1.87\%$

FEATURES

Balanced tonality ideal for 2-way speakers
 High efficiency
 Water resistant paper cone
 Optimized parameters for compact cabinets

SPECIFICATIONS

Nominal diameter = 320mm (12 inch)
 Nominal Impedance = 8 ohms
 Power handling = 500W RMS (AES Standard)
 Sensitivity = 97 dB / 1W / 1m
 Voice coil diameter = 3 inch (75mm)
 Voice coil height $H_{vc} = 20.5\text{mm}$
 Voice coil air gap $H_{ag} = 9\text{mm}$
 $X_{max} (H_{vc}-H_{ag})/2 + H_{ag}/4 = \pm 8\text{mm}$
 $X_{mech} \text{ (peak-peak)} = 40\text{mm}$
 Voice coil winding = 2 layers IN / OUT
 Voice coil material = 240°C Thermal Class CCAW
 Voice coil former = BAF fiberglass
 Suspension = Triple roll, impregnated fabric
 Spider = single, cold formed NOMEX®
 Cone = fiber loaded, waterproof treated paper
 Chassis = Die Cast Aluminum
 Magnet = Ø180mm Y30 Ferrite

MOUNTING & SHIPPING

Overall diameter = 315 mm
 Bolt circle diameter = 302 mm (8*M5)
 Baffle cutout diameter = 282 mm
 Flange and gasket thickness = 10 mm
 Overall depth = 139 mm
 Net weight = 6 kg
 Shipping weight = 7 kg
 Shipping box = 350x310x180 mm

FREQUENCY RESPONSE

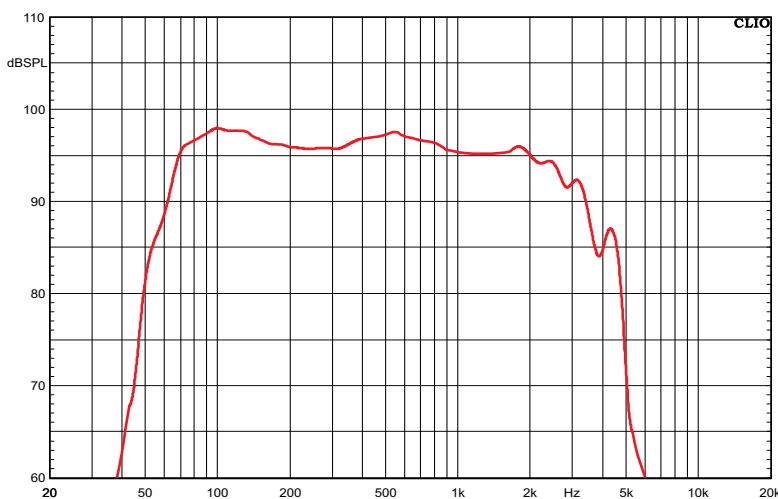

Woofer inside recommended cabinet (60 liters tuned at 55Hz), 2PI

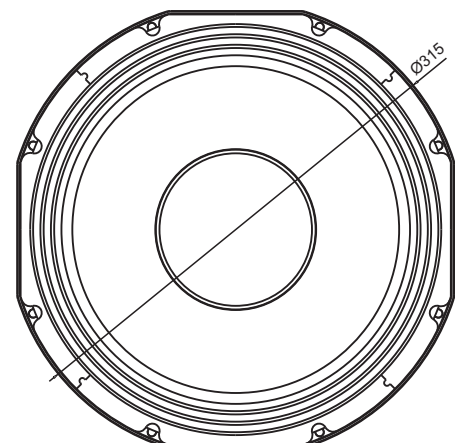
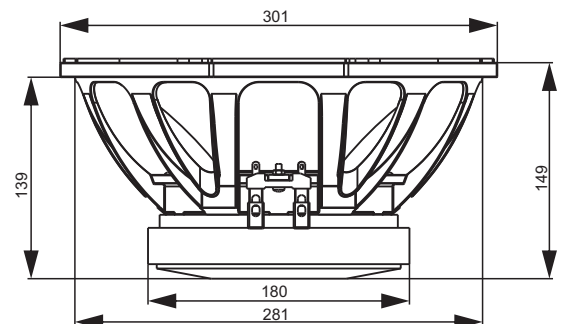

Important remarks:

1. Power handling is 2 hours test according to AES 2-1984 Rev. 2003
2. X_{mech} is maximum excursion before damage
3. Thiele-Small parameters are measured after 2 hours of high level 20 Hz sine wave pre-conditioning test.
4. Manufacturing tolerance: $F_s \pm 5\text{Hz}$ and $R_e \pm 0.4 \text{ ohm}$